



A TEREX BRAND

PRODUCT SPECIFICATION

5800BT

HORIZONTAL GRINDER



WHOLE TREES • STORM DEBRIS • SLASH • STUMPS • REGRIND

KEY FEATURES...

No other horizontal wood grinder cures the headaches of load restrictions and permitting as much as the CBI Magnum Force 5800BT Portable Upswing Grinder. This portable horizontal grinder was developed to feature the same principles of the proven CBI 6800BT Grinder but is purpose-built for contractors dealing with transportation restrictions.

Built to reduce the customer's total cost, replaceable 1" thick Hardox 450 wear liners fully protect the inside of the grinding chamber and simplify maintenance. Other features include a 30" diameter upper feed roller with a built in high-torque hydraulic motor, hydraulic up and down pressure, and 20 weld-on hammers with bolt-on reversible tips. Tips are arranged in a patented offset helix pattern that cuts the full width of the rotor, drastically increasing throughput over the competition's conventional pinned rotor design. The offset helix pattern promotes even wear across the rotor, so the customer spends more time grinding and less time changing teeth and screens.

CBI's Replace-A-Face™ hammer system allows operators to swap out the face independent of the rest of the hammer for quick, easy, and inexpensive repairs. Different tip widths and heights are available to change the cutting gap for a variety of grinding applications. The upper feed roll pivot also has replaceable wear plates. The rotor housing features the same spider bracing, rugged bearing housing, and cross members as CBI's larger machines. All holes are line-bored to the highest tolerances, ensuring long bearing life and that parts fit for the life of the machine. The rotor adheres to CBI's proven formulas for geometry and speed to maximize production rates while maintaining fuel economy.

48" wide cleated discharge belt provides unrestricted discharge of ground product.

Upper feed roller; high-torque hydraulic motor built into roller.

CAT C-18, 765 HP engine.



Hardox 450 recessed bolt-in sideliners for a smooth transition of processed material.

Large capacity feed hopper that handles full-length trees or large material surges with no problem.

Metal Detection System to protect rotor, anvil, and screens.

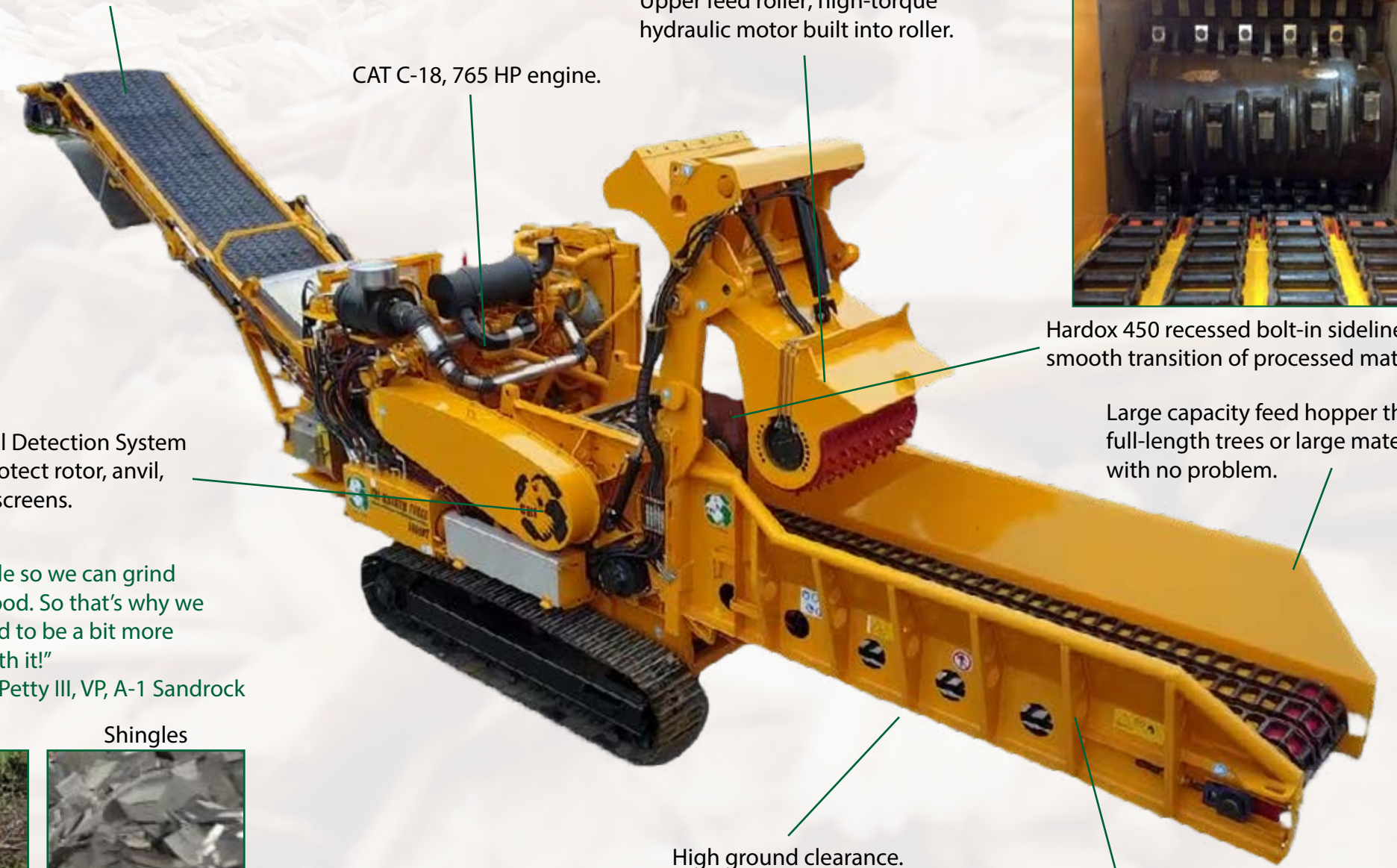

High ground clearance.

AR 450 construction.



"We looked for a machine that's versatile so we can grind shingles and switch back and grind wood. So that's why we went with a 5800BT because we wanted to be a bit more versatile. We're having great success with it!"

---Ronnie Petty III, VP, A-1 Sandrock

Pallets

Stumps

Logs

Brush

Shingles

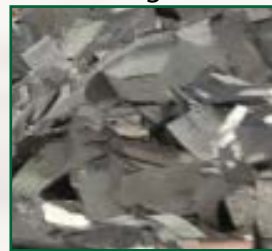
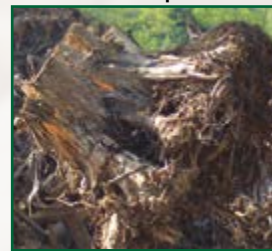

With minimal transportation restrictions, this machine is a major plus for contractors moving from job to job.



IQAN electric, hydraulic controls



Grinder chamber opens in seconds



Various hammer inserts



METAL DETECTION SYSTEM



A problem for any industrial grinder has to do with tramp metal entering the grinder chamber and causing significant damage, which leads to downtime. The Metal Detection System™ (MDS) engages within milliseconds whenever the grinder's rotor makes contact with tramp metal.

The rotor is monitored by an electronic sensor to alert the control system when tramp metal is detected. It will automatically idle down the engine to a controlled shut down, raise the top feed roller, and reverse the infeed to allow the operator to find the tramp metal.

TRANSPORT DIMENSIONS

Width: 8'-4" (2,540mm)
Height: 12'-0" (3,657mm)
Length: 38'-11" (11,860mm)
Weight: 63,000 - 69,000 lbs. (approx.)

DISCHARGE CONVEYOR

Width: 48" (1,219mm)
Length: 36' (10,972mm)
Height: 15'4" (4,675mm)
Motor: Char-Lynn hydraulic motor

INFEED

Width: 48" (1,219mm)
Conveyor: 16'-0" (4,876mm), 4 strands heavy-duty drag chain

ENGINE/DRIVE

Caterpillar C-18; 765-HP (570 kW)
8 groove, 8-V section
Kevlar belts with guarding

CONTROLS

Parker IQAN™
Remote control operated

ROTOR

Shaft: 6" (152mm)
Width: 48" (1,219mm)
Diameter: 40" (1,016mm)
Top Feed Roll: 30" D x 48" W

FAN

Reversing pitch radiator fan that reverses airflow automatically

OPTIONS

Overband Magnet
Lighting Package
Control Panel Guard
Air Compressor w/ enclosure
Single or Double Grouser Pad
Caterpillar C-18; 755 Tier 4 Final

Specification subject to change without notice.

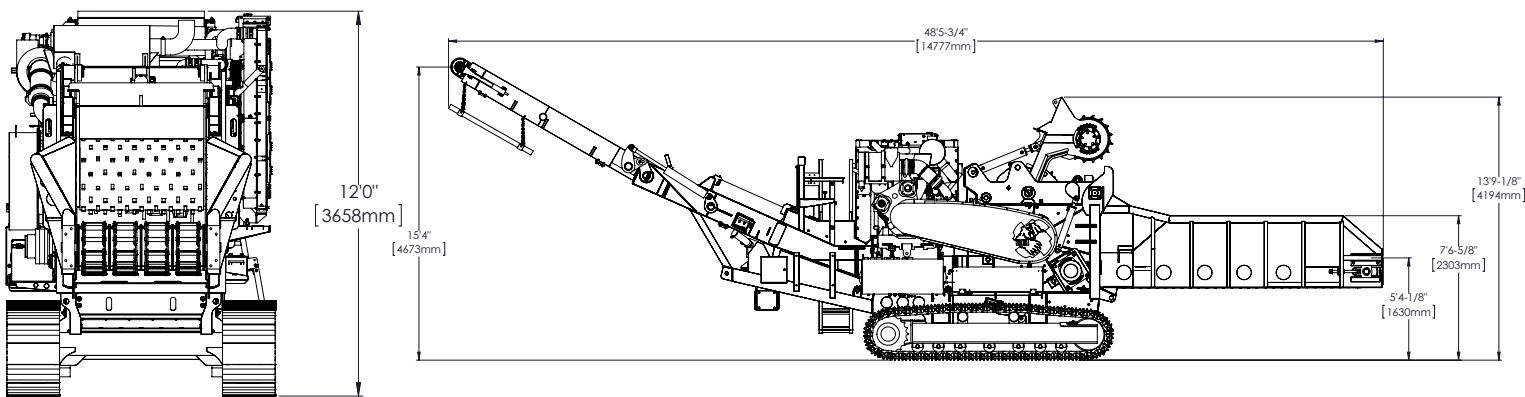

CONTINENTAL BIOMASS INDUSTRIES

World's best stationary and portable material recovery systems.

22 Whittier Street, Newton, NH, 03858
Phone: (603) 382-0556 Fax: (603) 382-0557

Web: www.terex.com/cbi Email: NWT.InfoFWD@terex.com

Distributed by: